



# IF-20EI-1 Sprayer Information

**IF** CHOOSE  
**OUR** PRODUCT  
**NI**CE SERVICE  
ALWAYS  
AROUND  
YOU



## **New Electric Sprayer IF-20EI-1**

1 **Product Certification**

2 **Product Introduction**

2 **Product Advantages**

## Product Certification



The new electric sprayer is independently developed and designed by our company. It has patented utility model and design.



# Product Certification

The new electric sprayer has got international certifications of CE、FCC、ROHS and UKCA.

Certificate - Сертификат - 證明書 - Certificat - 증명서 - 合格證書

Form QAT\_1 QM05, version 00, effective since March 25th, 2021

## Certificate of Compliance

No. 4A220418.II.US.45  
Test Report / Technical Construction file no. BK.C22040901.DE, BK.C22040902.DS

**Certificate Holder:** Fourni Technology Co., Ltd.  
Room 911, Technology Innovation Center, No.2 Chenguang Road, Saihan District, Hohhot, Inner Mongolia, China

**Certification ECM Mark:**

**Product:** Sprayer  
**Trademark:** Fourni  
**Model(s):** (see the following annex)

**Verification to:** Standard: EN IEC 55014-1:2021, EN IEC 61000-3-2:2019+A1:2021, EN 61000-3-3:2013+A1:2019, EN IEC 55014-2:2021, EN 60335-1:2012+A11:2014+A13:2017+A1:2019+A2:2019+A1:4:2019+A1:5:2021

related to CE Directive(s):  
2014/35/EU (Low Voltage)  
2014/30/EU (Electromagnetic Compatibility)

**Remark:** This document has been issued on a voluntary basis and upon request of the manufacturer. It is our opinion that the technical documentation revealed from the manufacturer is satisfactory for the requirements of the ECM Certification Mark. The conformity mark above can be affixed on the products accordingly to the ECM regulation about its release and its use.

**Additional information and clarification about the Marking:**  
The manufacturer is responsible for the CE Marking process, and if necessary, must refer to a notified body. This document has been issued on the basis of the regulation on ECM Voluntary Mark for the certification of products. R001\_ECM rev.3 available at: www.entecem.com

**CE**  
Issuance date: 18 April 2022  
Expiry date: 17 April 2027

**Approver:** Amanda Payne (Technical expert), Luca Bedonni (ECM Service Director)

**Entecem**  
Entecem Certification Macchine S.p.A.  
Via Cassinetta, 43 - Loc. Casella di Senavalle - 40053 Valsamoggia (BO) - Italy  
+39 051 6705141 +39 051 6705156 info@entecem.com www.entecem.it

CERTIFICATE OF CONFORMITY

## Supplier's Declaration of Conformity

**Certificate No.:** BKC22040811DC

**Applicant:** Fourni Technology Co., Ltd.  
Room 911, Technology Innovation Center, No.2 Chenguang Road, Saihan District, Hohhot, Inner Mongolia, China

**Manufacturer:** Fourni Technology Co., Ltd.  
Room 911, Technology Innovation Center, No.2 Chenguang Road, Saihan District, Hohhot, Inner Mongolia, China

**Trademark:** Fourni  
**Product:** Sprayer  
**Model(s):** IF-20E1-1, IF-16EA-1, IF-16EA-2, IF-18EA-1, IF-18EA-2, IF-20EA-1, IF-20EA-2, IF-16EB-1, IF-16EB-2, IF-18EB-1, IF-18EB-2, IF-20EB-1, IF-20EB-2, IF-16EC-1, IF-16EC-2, IF-20EC-1, IF-20EC-2, IF-16ED-1, IF-16ED-2, IF-20ED-1, IF-20ED-2, IF-16EE-1, IF-20EE-1, IF-16EE-2, IF-20EE-2, IF-16EF-1, IF-20EF-1, IF-16EG-1, IF-20EG-1, IF-16EH-1, IF-16EH-2, IF-20EH-1, IF-20EH-2, IF-16EI-1, IF-16EI-2, IF-20EI-1, IF-20EI-2, IF-16EJ-1, IF-16EJ-2, IF-20EJ-1, IF-20EJ-2, IF-16EK-1, IF-16EK-2, IF-20EK-1, IF-20EK-2, IF-16EL-1, IF-16EL-2, IF-20EL-1, IF-20EL-2, IF-16EM-1, IF-16EM-2, IF-20EM-1, IF-20EM-2, IF-16EN-1, IF-16EN-2, IF-20EN-1, IF-20EN-2, IF-16EO-1, IF-16EO-2, IF-20EO-1, IF-20EO-2, IF-16EP-1, IF-16EP-2, IF-20EP-1, IF-20EP-2, IF-16EQ-1, IF-16EQ-2, IF-20EQ-1, IF-20EQ-2, IF-16ER-1, IF-16ER-2, IF-20ER-1, IF-20ER-2, IF-16ES-1, IF-16ES-2, IF-20ES-1, IF-20ES-2, IF-16ET-1, IF-16ET-2, IF-20ET-1, IF-20ET-2, IF-16EU-1, IF-16EU-2, IF-20EU-1, IF-20EU-2, IF-16EV-1, IF-16EV-2, IF-20EV-1, IF-20EV-2, IF-16EW-1, IF-16EW-2, IF-20EW-1, IF-20EW-2, IF-16EX-1, IF-16EX-2, IF-20EX-1, IF-20EX-2, IF-16EY-1, IF-16EY-2, IF-20EY-1, IF-20EY-2, IF-16EZ-1, IF-16EZ-2, IF-20EZ-1, IF-20EZ-2, IF-16FA-1, IF-16FA-2, IF-20FA-1, IF-20FA-2, IF-16FB-1, IF-16FB-2, IF-20FB-1, IF-20FB-2, IF-16FC-1, IF-16FC-2, IF-20FC-1, IF-20FC-2, IF-16FD-1, IF-16FD-2, IF-20FD-1, IF-20FD-2, IF-16FE-1, IF-16FE-2, IF-20FE-1, IF-20FE-2, IF-16FF-1, IF-16FF-2, IF-20FF-1, IF-20FF-2, IF-16FG-1, IF-16FG-2, IF-20FG-1, IF-20FG-2, IF-16FH-1, IF-16FH-2, IF-20FH-1, IF-20FH-2, IF-16FI-1, IF-16FI-2, IF-20FI-1, IF-20FI-2, IF-16FJ-1, IF-16FJ-2, IF-20FJ-1, IF-20FJ-2, IF-16FK-1, IF-16FK-2, IF-20FK-1, IF-20FK-2, IF-16FL-1, IF-16FL-2, IF-20FL-1, IF-20FL-2, IF-16FM-1, IF-16FM-2, IF-20FM-1, IF-20FM-2, IF-16FN-1, IF-16FN-2, IF-20FN-1, IF-20FN-2, IF-16FO-1, IF-16FO-2, IF-20FO-1, IF-20FO-2, IF-16FP-1, IF-16FP-2, IF-20FP-1, IF-20FP-2, IF-16FQ-1, IF-16FQ-2, IF-20FQ-1, IF-20FQ-2, IF-16FR-1, IF-16FR-2, IF-20FR-1, IF-20FR-2, IF-16FS-1, IF-16FS-2, IF-20FS-1, IF-20FS-2, IF-16FT-1, IF-16FT-2, IF-20FT-1, IF-20FT-2, IF-16FU-1, IF-16FU-2, IF-20FU-1, IF-20FU-2, IF-16FV-1, IF-16FV-2, IF-20FV-1, IF-20FV-2, IF-16FW-1, IF-16FW-2, IF-20FW-1, IF-20FW-2, IF-16FX-1, IF-16FX-2, IF-20FX-1, IF-20FX-2, IF-16FY-1, IF-16FY-2, IF-20FY-1, IF-20FY-2, IF-16FZ-1, IF-16FZ-2, IF-20FZ-1, IF-20FZ-2, IF-16GA-1, IF-16GA-2, IF-20GA-1, IF-20GA-2, IF-16GB-1, IF-16GB-2, IF-20GB-1, IF-20GB-2, IF-16GC-1, IF-16GC-2, IF-20GC-1, IF-20GC-2, IF-16GD-1, IF-16GD-2, IF-20GD-1, IF-20GD-2, IF-16GE-1, IF-16GE-2, IF-20GE-1, IF-20GE-2, IF-16GF-1, IF-16GF-2, IF-20GF-1, IF-20GF-2, IF-16GH-1, IF-16GH-2, IF-20GH-1, IF-20GH-2, IF-16GI-1, IF-16GI-2, IF-20GI-1, IF-20GI-2, IF-16GJ-1, IF-16GJ-2, IF-20GJ-1, IF-20GJ-2, IF-16GK-1, IF-16GK-2, IF-20GK-1, IF-20GK-2, IF-16GL-1, IF-16GL-2, IF-20GL-1, IF-20GL-2, IF-16GM-1, IF-16GM-2, IF-20GM-1, IF-20GM-2, IF-16GN-1, IF-16GN-2, IF-20GN-1, IF-20GN-2, IF-16GO-1, IF-16GO-2, IF-20GO-1, IF-20GO-2, IF-16GP-1, IF-16GP-2, IF-20GP-1, IF-20GP-2, IF-16GQ-1, IF-16GQ-2, IF-20GQ-1, IF-20GQ-2, IF-16GR-1, IF-16GR-2, IF-20GR-1, IF-20GR-2, IF-16GS-1, IF-16GS-2, IF-20GS-1, IF-20GS-2, IF-16GT-1, IF-16GT-2, IF-20GT-1, IF-20GT-2, IF-16GU-1, IF-16GU-2, IF-20GU-1, IF-20GU-2, IF-16GV-1, IF-16GV-2, IF-20GV-1, IF-20GV-2, IF-16GW-1, IF-16GW-2, IF-20GW-1, IF-20GW-2, IF-16GX-1, IF-16GX-2, IF-20GX-1, IF-20GX-2, IF-16GY-1, IF-16GY-2, IF-20GY-1, IF-20GY-2, IF-16GZ-1, IF-16GZ-2, IF-20GZ-1, IF-20GZ-2, IF-16HA-1, IF-16HA-2, IF-20HA-1, IF-20HA-2, IF-16HB-1, IF-16HB-2, IF-20HB-1, IF-20HB-2, IF-16HC-1, IF-16HC-2, IF-20HC-1, IF-20HC-2, IF-16HD-1, IF-16HD-2, IF-20HD-1, IF-20HD-2, IF-16HE-1, IF-16HE-2, IF-20HE-1, IF-20HE-2, IF-16HF-1, IF-16HF-2, IF-20HF-1, IF-20HF-2, IF-16HG-1, IF-16HG-2, IF-20HG-1, IF-20HG-2, IF-16HH-1, IF-16HH-2, IF-20HH-1, IF-20HH-2, IF-16HI-1, IF-16HI-2, IF-20HI-1, IF-20HI-2, IF-16HJ-1, IF-16HJ-2, IF-20HJ-1, IF-20HJ-2, IF-16HK-1, IF-16HK-2, IF-20HK-1, IF-20HK-2, IF-16HL-1, IF-16HL-2, IF-20HL-1, IF-20HL-2, IF-16HM-1, IF-16HM-2, IF-20HM-1, IF-20HM-2, IF-16HN-1, IF-16HN-2, IF-20HN-1, IF-20HN-2, IF-16HO-1, IF-16HO-2, IF-20HO-1, IF-20HO-2, IF-16HP-1, IF-16HP-2, IF-20HP-1, IF-20HP-2, IF-16HQ-1, IF-16HQ-2, IF-20HQ-1, IF-20HQ-2, IF-16HR-1, IF-16HR-2, IF-20HR-1, IF-20HR-2, IF-16HS-1, IF-16HS-2, IF-20HS-1, IF-20HS-2, IF-16HT-1, IF-16HT-2, IF-20HT-1, IF-20HT-2, IF-16HU-1, IF-16HU-2, IF-20HU-1, IF-20HU-2, IF-16HV-1, IF-16HV-2, IF-20HV-1, IF-20HV-2, IF-16HW-1, IF-16HW-2, IF-20HW-1, IF-20HW-2, IF-16HX-1, IF-16HX-2, IF-20HX-1, IF-20HX-2, IF-16HY-1, IF-16HY-2, IF-20HY-1, IF-20HY-2, IF-16HZ-1, IF-16HZ-2, IF-20HZ-1, IF-20HZ-2, IF-16IA-1, IF-16IA-2, IF-20IA-1, IF-20IA-2, IF-16IB-1, IF-16IB-2, IF-20IB-1, IF-20IB-2, IF-16IC-1, IF-16IC-2, IF-20IC-1, IF-20IC-2, IF-16ID-1, IF-16ID-2, IF-20ID-1, IF-20ID-2, IF-16IE-1, IF-16IE-2, IF-20IE-1, IF-20IE-2, IF-16IF-1, IF-16IF-2, IF-20IF-1, IF-20IF-2, IF-16IG-1, IF-16IG-2, IF-20IG-1, IF-20IG-2, IF-16IH-1, IF-16IH-2, IF-20IH-1, IF-20IH-2, IF-16II-1, IF-16II-2, IF-20II-1, IF-20II-2, IF-16IJ-1, IF-16IJ-2, IF-20IJ-1, IF-20IJ-2, IF-16IK-1, IF-16IK-2, IF-20IK-1, IF-20IK-2, IF-16IL-1, IF-16IL-2, IF-20IL-1, IF-20IL-2, IF-16IM-1, IF-16IM-2, IF-20IM-1, IF-20IM-2, IF-16IN-1, IF-16IN-2, IF-20IN-1, IF-20IN-2, IF-16IO-1, IF-16IO-2, IF-20IO-1, IF-20IO-2, IF-16IP-1, IF-16IP-2, IF-20IP-1, IF-20IP-2, IF-16IQ-1, IF-16IQ-2, IF-20IQ-1, IF-20IQ-2, IF-16IR-1, IF-16IR-2, IF-20IR-1, IF-20IR-2, IF-16IS-1, IF-16IS-2, IF-20IS-1, IF-20IS-2, IF-16IT-1, IF-16IT-2, IF-20IT-1, IF-20IT-2, IF-16IU-1, IF-16IU-2, IF-20IU-1, IF-20IU-2, IF-16IV-1, IF-16IV-2, IF-20IV-1, IF-20IV-2, IF-16IW-1, IF-16IW-2, IF-20IW-1, IF-20IW-2, IF-16IX-1, IF-16IX-2, IF-20IX-1, IF-20IX-2, IF-16IY-1, IF-16IY-2, IF-20IY-1, IF-20IY-2, IF-16IZ-1, IF-16IZ-2, IF-20IZ-1, IF-20IZ-2, IF-16JA-1, IF-16JA-2, IF-20JA-1, IF-20JA-2, IF-16JB-1, IF-16JB-2, IF-20JB-1, IF-20JB-2, IF-16JC-1, IF-16JC-2, IF-20JC-1, IF-20JC-2, IF-16JD-1, IF-16JD-2, IF-20JD-1, IF-20JD-2, IF-16JE-1, IF-16JE-2, IF-20JE-1, IF-20JE-2, IF-16JF-1, IF-16JF-2, IF-20JF-1, IF-20JF-2, IF-16JG-1, IF-16JG-2, IF-20JG-1, IF-20JG-2, IF-16JH-1, IF-16JH-2, IF-20JH-1, IF-20JH-2, IF-16JI-1, IF-16JI-2, IF-20JI-1, IF-20JI-2, IF-16JK-1, IF-16JK-2, IF-20JK-1, IF-20JK-2, IF-16JL-1, IF-16JL-2, IF-20JL-1, IF-20JL-2, IF-16JM-1, IF-16JM-2, IF-20JM-1, IF-20JM-2, IF-16JN-1, IF-16JN-2, IF-20JN-1, IF-20JN-2, IF-16JO-1, IF-16JO-2, IF-20JO-1, IF-20JO-2, IF-16JP-1, IF-16JP-2, IF-20JP-1, IF-20JP-2, IF-16JQ-1, IF-16JQ-2, IF-20JQ-1, IF-20JQ-2, IF-16JR-1, IF-16JR-2, IF-20JR-1, IF-20JR-2, IF-16JS-1, IF-16JS-2, IF-20JS-1, IF-20JS-2, IF-16JT-1, IF-16JT-2, IF-20JT-1, IF-20JT-2, IF-16JU-1, IF-16JU-2, IF-20JU-1, IF-20JU-2, IF-16JV-1, IF-16JV-2, IF-20JV-1, IF-20JV-2, IF-16JW-1, IF-16JW-2, IF-20JW-1, IF-20JW-2, IF-16JX-1, IF-16JX-2, IF-20JX-1, IF-20JX-2, IF-16JY-1, IF-16JY-2, IF-20JY-1, IF-20JY-2, IF-16JZ-1, IF-16JZ-2, IF-20JZ-1, IF-20JZ-2, IF-16KA-1, IF-16KA-2, IF-20KA-1, IF-20KA-2, IF-16KB-1, IF-16KB-2, IF-20KB-1, IF-20KB-2, IF-16KC-1, IF-16KC-2, IF-20KC-1, IF-20KC-2, IF-16KD-1, IF-16KD-2, IF-20KD-1, IF-20KD-2, IF-16KE-1, IF-16KE-2, IF-20KE-1, IF-20KE-2, IF-16KF-1, IF-16KF-2, IF-20KF-1, IF-20KF-2, IF-16KG-1, IF-16KG-2, IF-20KG-1, IF-20KG-2, IF-16KH-1, IF-16KH-2, IF-20KH-1, IF-20KH-2, IF-16KI-1, IF-16KI-2, IF-20KI-1, IF-20KI-2, IF-16KL-1, IF-16KL-2, IF-20KL-1, IF-20KL-2, IF-16KM-1, IF-16KM-2, IF-20KM-1, IF-20KM-2, IF-16KN-1, IF-16KN-2, IF-20KN-1, IF-20KN-2, IF-16KO-1, IF-16KO-2, IF-20KO-1, IF-20KO-2, IF-16KP-1, IF-16KP-2, IF-20KP-1, IF-20KP-2, IF-16KQ-1, IF-16KQ-2, IF-20KQ-1, IF-20KQ-2, IF-16KR-1, IF-16KR-2, IF-20KR-1, IF-20KR-2, IF-16KS-1, IF-16KS-2, IF-20KS-1, IF-20KS-2, IF-16KT-1, IF-16KT-2, IF-20KT-1, IF-20KT-2, IF-16KU-1, IF-16KU-2, IF-20KU-1, IF-20KU-2, IF-16KV-1, IF-16KV-2, IF-20KV-1, IF-20KV-2, IF-16KW-1, IF-16KW-2, IF-20KW-1, IF-20KW-2, IF-16KX-1, IF-16KX-2, IF-20KX-1, IF-20KX-2, IF-16KY-1, IF-16KY-2, IF-20KY-1, IF-20KY-2, IF-16KZ-1, IF-16KZ-2, IF-20KZ-1, IF-20KZ-2, IF-16LA-1, IF-16LA-2, IF-20LA-1, IF-20LA-2, IF-16LB-1, IF-16LB-2, IF-20LB-1, IF-20LB-2, IF-16LC-1, IF-16LC-2, IF-20LC-1, IF-20LC-2, IF-16LD-1, IF-16LD-2, IF-20LD-1, IF-20LD-2, IF-16LE-1, IF-16LE-2, IF-20LE-1, IF-20LE-2, IF-16LF-1, IF-16LF-2, IF-20LF-1, IF-20LF-2, IF-16LG-1, IF-16LG-2, IF-20LG-1, IF-20LG-2, IF-16LH-1, IF-16LH-2, IF-20LH-1, IF-20LH-2, IF-16LI-1, IF-16LI-2, IF-20LI-1, IF-20LI-2, IF-16LJ-1, IF-16LJ-2, IF-20LJ-1, IF-20LJ-2, IF-16LK-1, IF-16LK-2, IF-20LK-1, IF-20LK-2, IF-16LL-1, IF-16LL-2, IF-20LL-1, IF-20LL-2, IF-16LM-1, IF-16LM-2, IF-20LM-1, IF-20LM-2, IF-16LN-1, IF-16LN-2, IF-20LN-1, IF-20LN-2, IF-16LO-1, IF-16LO-2, IF-20LO-1, IF-20LO-2, IF-16LP-1, IF-16LP-2, IF-20LP-1, IF-20LP-2, IF-16LQ-1, IF-16LQ-2, IF-20LQ-1, IF-20LQ-2, IF-16LR-1, IF-16LR-2, IF-20LR-1, IF-20LR-2, IF-16LS-1, IF-16LS-2, IF-20LS-1, IF-20LS-2, IF-16LT-1, IF-16LT-2, IF-20LT-1, IF-20LT-2, IF-16LU-1, IF-16LU-2, IF-20LU-1, IF-20LU-2, IF-16LV-1, IF-16LV-2, IF-20LV-1, IF-20LV-2, IF-16LW-1, IF-16LW-2, IF-20LW-1, IF-20LW-2, IF-16LX-1, IF-16LX-2, IF-20LX-1, IF-20LX-2, IF-16LY-1, IF-16LY-2, IF-20LY-1, IF-20LY-2, IF-16LZ-1, IF-16LZ-2, IF-20LZ-1, IF-20LZ-2, IF-16MA-1, IF-16MA-2, IF-20MA-1, IF-20MA-2, IF-16MB-1, IF-16MB-2, IF-20MB-1, IF-20MB-2, IF-16MC-1, IF-16MC-2, IF-20MC-1, IF-20MC-2, IF-16MD-1, IF-16MD-2, IF-20MD-1, IF-20MD-2, IF-16ME-1, IF-16ME-2, IF-20ME-1, IF-20ME-2, IF-16MF-1, IF-16MF-2, IF-20MF-1, IF-20MF-2, IF-16MG-1, IF-16MG-2, IF-20MG-1, IF-20MG-2, IF-16MH-1, IF-16MH-2, IF-20MH-1, IF-20MH-2, IF-16MI-1, IF-16MI-2, IF-20MI-1, IF-20MI-2, IF-16MJ-1, IF-16MJ-2, IF-20MJ-1, IF-20MJ-2, IF-16MK-1, IF-16MK-2, IF-20MK-1, IF-20MK-2, IF-16ML-1, IF-16ML-2, IF-20ML-1, IF-20ML-2, IF-16MM-1, IF-16MM-2, IF-20MM-1, IF-20MM-2, IF-16MN-1, IF-16MN-2, IF-20MN-1, IF-20MN-2, IF-16MO-1, IF-16MO-2, IF-20MO-1, IF-20MO-2, IF-16MP-1, IF-16MP-2, IF-20MP-1, IF-20MP-2, IF-16MQ-1, IF-16MQ-2, IF-20MQ-1, IF-20MQ-2, IF-16MR-1, IF-16MR-2, IF-20MR-1, IF-20MR-2, IF-16MS-1, IF-16MS-2, IF-20MS-1, IF-20MS-2, IF-16MT-1, IF-16MT-2, IF-20MT-1, IF-20MT-2, IF-16MU-1, IF-16MU-2, IF-20MU-1, IF-20MU-2, IF-16MV-1, IF-16MV-2, IF-20MV-1, IF-20MV-2, IF-16MW-1, IF-16MW-2, IF-20MW-1, IF-20MW-2, IF-16MX-1, IF-16MX-2, IF-20MX-1, IF-20MX-2, IF-16MY-1, IF-16MY-2, IF-20MY-1, IF-20MY-2, IF-16MZ-1, IF-16MZ-2, IF-20MZ-1, IF-20MZ-2, IF-16NA-1, IF-16NA-2, IF-20NA-1, IF-20NA-2, IF-16NB-1, IF-16NB-2, IF-20NB-1, IF-20NB-2, IF-16NC-1, IF-16NC-2, IF-20NC-1, IF-20NC-2, IF-16ND-1, IF-16ND-2, IF-20ND-1, IF-20ND-2, IF-16NE-1, IF-16NE-2, IF-20NE-1, IF-20NE-2, IF-16NF-1, IF-16NF-2, IF-20NF-1, IF-20NF-2, IF-16NG-1, IF-16NG-2, IF-20NG-1, IF-20NG-2, IF-16NH-1, IF-16NH-2, IF-20NH-1, IF-20NH-2, IF-16NI-1, IF-16NI-2, IF-20NI-1, IF-20NI-2, IF-16NJ-1, IF-16NJ-2, IF-20NJ-1, IF-20NJ-2, IF-16NK-1, IF-16NK-2, IF-20NK-1, IF-20NK-2, IF-16NL-1, IF-16NL-2, IF-20NL-1, IF-20NL-2, IF-16NM-1, IF-16NM-2, IF-20NM-1, IF-20NM-2, IF-16NN-1, IF-16NN-2, IF-20NN-1, IF-20NN-2, IF-16NO-1, IF-16NO-2, IF-20NO-1, IF-20NO-2, IF-16NP-1, IF-16NP-2, IF-20NP-1, IF-20NP-2, IF-16NQ-1, IF-16NQ-2, IF-20NQ-1, IF-20NQ-2, IF-16NR-1, IF-16NR-2, IF-20NR-1, IF-20NR-2, IF-16NS-1, IF-16NS-2, IF-20NS-1, IF-20NS-2, IF-16NT-1, IF-16NT-2, IF-20NT-1, IF-20NT-2, IF-16NU-1, IF-16NU-2, IF-20NU-1, IF-20NU-2, IF-16NV-1, IF-16NV-2, IF-20NV-1, IF-20NV-2, IF-16NW-1, IF-16NW-2, IF-20NW-1, IF-20NW-2, IF-16NX-1, IF-16NX-2, IF-20NX-1, IF-20NX-2, IF-16NY-1, IF-16NY-2, IF-20NY-1, IF-20NY-2, IF-16NZ-1, IF-16NZ-2, IF-20NZ-1, IF-20NZ-2, IF-16OA-1, IF-16OA-2, IF-20OA-1, IF-20OA-2, IF-16OB-1, IF-16OB-2, IF-20OB-1, IF-20OB-2, IF-16OC-1, IF-16OC-2, IF-20OC-1, IF-20OC-2, IF-16OD-1, IF-16OD-2, IF-20OD-1, IF-20OD-2, IF-16OE-1, IF-16OE-2, IF-20OE-1, IF-20OE-2, IF-16OF-1, IF-16OF-2, IF-20OF-1, IF-20OF-2, IF-16OG-1, IF-16OG-2, IF-20OG-1, IF-20OG-2, IF-16OH-1, IF-16OH-2, IF-20OH-1, IF-20OH-2, IF-16OI-1, IF-16OI-2, IF-20OI-1, IF-20OI-2, IF-16OJ-1, IF-16OJ-2, IF-20OJ-1, IF-20OJ-2, IF-16OK-1, IF-16OK-2, IF-20OK-1, IF-20OK-2, IF-16OL-1, IF-16OL-2, IF-20OL-1, IF-20OL-2, IF-16OM-1, IF-16OM-2, IF-20OM-1, IF-20OM-2, IF-16ON-1, IF-16ON-2, IF-20ON-1, IF-20ON-2, IF-16OO-1, IF-16OO-2, IF-20OO-1, IF-20OO-2, IF-16OP-1, IF-16OP-2, IF-20OP-1, IF-20OP-2, IF-16OQ-1, IF-16OQ-2, IF-20OQ-1, IF-20OQ-2, IF-16OR-1, IF-16OR-2, IF-20OR-1, IF-20OR-2, IF-16OS-1, IF-16OS-2, IF-20OS-1, IF-20OS-2, IF-16OT-1, IF-16OT-2, IF-20OT-1, IF-20OT-2, IF-16OU-1, IF-16OU-2, IF-20OU-1, IF-20OU-2, IF-16OV-1, IF-16OV-2, IF-20OV-1, IF-20OV-2, IF-16OW-1, IF-16OW-2, IF-20OW-1, IF-20OW-2, IF-16OX-1, IF-16OX-2, IF-20OX-1, IF-20OX-2, IF-16OY-1, IF-16OY-2, IF-20OY-1, IF-20OY-2, IF-16OZ-1, IF-16OZ-2, IF-20OZ-1, IF-20OZ-2, IF-16PA-1, IF-16PA-2, IF-20PA-1, IF-20PA-2, IF-16PB-1, IF-16PB-2, IF-20PB-1, IF-20PB-2, IF-16PC-1, IF-16PC-2, IF-20PC-1, IF-20PC-2, IF-16PD-1, IF-16PD-2, IF-20PD-1, IF-20PD-2, IF-16PE-1, IF-16PE-2, IF-20PE-1, IF-20PE-2, IF-16PF-1, IF-16PF-2, IF-20PF-1, IF-20PF-2, IF-16PG-1, IF-16PG-2, IF-20PG-1, IF-20PG-2, IF-16PH-1, IF-16PH-2, IF-20PH-1, IF-20PH-2, IF-16PI-1, IF-16PI-2, IF-20PI-1, IF-20PI-2, IF-16PJ-1, IF-16PJ-2, IF-20PJ-1, IF-20PJ-2, IF-16PK-1, IF-16PK-2, IF-20PK-1, IF-20PK-2, IF-16PL-1, IF-16PL-2, IF-20PL-1, IF-20PL-2, IF-16PM-1, IF-16PM-2, IF-20PM-1, IF-20PM-2, IF-16PN-1, IF-16PN-2, IF-20PN-1, IF-20PN-2, IF-16PO-1, IF-16PO-2, IF-20PO-1, IF-20PO-2, IF-16PP-1, IF-16PP-2, IF-20PP-1, IF-20PP-2, IF-16PQ-1, IF-16PQ-2, IF-20PQ-1, IF-20PQ-2, IF-16PR-1, IF-16PR-2, IF-20PR-1, IF-20PR-2, IF-16PS-1, IF-16PS-2, IF-20PS-1, IF-20PS-2, IF-16PT-1, IF-16PT-2, IF-20PT-1, IF-20PT-2, IF-16PU-1, IF-16PU-2, IF-20PU-1, IF-20PU-2, IF-16PV-1, IF-16PV-2, IF-20PV-1, IF-20PV-2, IF-16PW-1, IF-16PW-2, IF-20PW-1, IF-20PW-2, IF-16PX-1, IF-16PX-2, IF-20PX-1, IF-20PX-2, IF-16PY-1, IF-16PY-2, IF-20PY-1, IF-20PY-2, IF-16PZ-1, IF-16PZ-2, IF-20PZ-1, IF-20PZ-2, IF-16QA-1, IF-16QA-2, IF-20QA-1, IF-20QA-2, IF-16QB-1, IF-16QB-2, IF-20QB-1, IF-20QB-2, IF-16QC-1, IF-16QC-2, IF-20QC-1, IF-20QC-2, IF-16QD-1, IF-16QD-2, IF-20QD-1, IF-20QD-2, IF-16QE-1, IF-16QE-2, IF-20QE-1, IF-20QE-2, IF-16QF-1, IF-16QF-2, IF-20QF-1, IF-20QF-2, IF-16QG-1, IF-16QG-2, IF-20QG-1, IF-20QG-2, IF-16QH-1, IF-16QH-2, IF-20QH-1, IF-20QH-2, IF-16QI-1, IF-16QI-2, IF-20QI-1, IF-20QI-2, IF-16QJ-1, IF-16QJ-2, IF-20QJ-1, IF-20QJ-2, IF-16QK-1, IF-16QK-2, IF-20QK-1, IF-20QK-2, IF-16QL-1, IF-16QL-2, IF-20QL-1, IF-20QL-2, IF-16QM-1, IF-16QM-2, IF-20QM-1, IF-20QM-2, IF-16QN-1, IF-16QN-2, IF-20QN-1, IF-20QN-2, IF-16QO-1, IF-16QO-2, IF-20QO-1, IF-20QO-2, IF-16QP-1, IF-16QP-2, IF-20QP-1, IF-20QP-2, IF-16QQ-1, IF-16QQ-2, IF-20QQ-1, IF-20QQ-2, IF-16QR-1, IF-16QR-2, IF-20QR-1, IF-20QR-2, IF-16QS-1, IF-16QS-2, IF-20QS-1, IF-20QS-2, IF-16QT-1, IF-16QT-2, IF-20QT-1, IF-20QT-2, IF-16QU-1, IF-16QU-2, IF-20QU-1, IF-20QU-2, IF-16QV-1, IF-16QV-2, IF-20QV-1, IF-20QV-2, IF-16QW-1, IF-16QW-2, IF-20QW-1, IF-20QW-2, IF-16QX-1, IF-16QX-2, IF-20QX-1, IF-20QX-2, IF-16QY-1, IF-16QY-2, IF-20QY-1, IF-20QY-2, IF-16QZ-1, IF-16QZ-2, IF-20QZ-1, IF-20QZ-2, IF-16RA-1, IF-16RA-2, IF-20RA-1, IF-20RA-2, IF-16RB-1, IF-16RB-2, IF-20RB-1, IF-20RB-2, IF-16RC-1, IF-16RC-2, IF-20RC-1, IF-20RC-2, IF-16RD-1, IF-16RD-2, IF-20RD-1, IF-20RD-2, IF-16RE-1, IF-16RE-2, IF-20RE-1, IF-20RE-2, IF-16RF-1, IF-16RF-2, IF-20RF-1, IF-20RF-2, IF-16RG-1, IF-16RG-2, IF-20RG-1, IF-20RG-2, IF-16RH-1, IF-16RH-2, IF-20RH-1, IF-20RH-2, IF-16RI-1, IF-16RI-2, IF-20RI-1, IF-20RI-2, IF-16RJ-

## Product Introduction——Design

Technology and metallic is the main style, blend the elements of Transformers, and learn from the design of European shield



## Product Introduction——Structure Diagram

- ① Cover Cap: pp raw material
- ② Drain Valve: nitrile rubber
- ③ Sealing Ring: foamed rubber
- ④ Filtered: pp raw material
- ⑤ Lifting Handle: pp raw material
- ⑥ 20L Tank: HDPE
- ⑦ Spray Rod Clamp
- ⑧ Control Module Unit
- ⑨ Inside Small Filter
- ⑩ Complete Tank Base
- ⑪ Lithium Battery Base: flame retardant nylon& brass
- ⑫ Lithium Battery
- ⑬ Pressure Pump
- ⑭ Battery Cover
- ⑮ Lower Cap

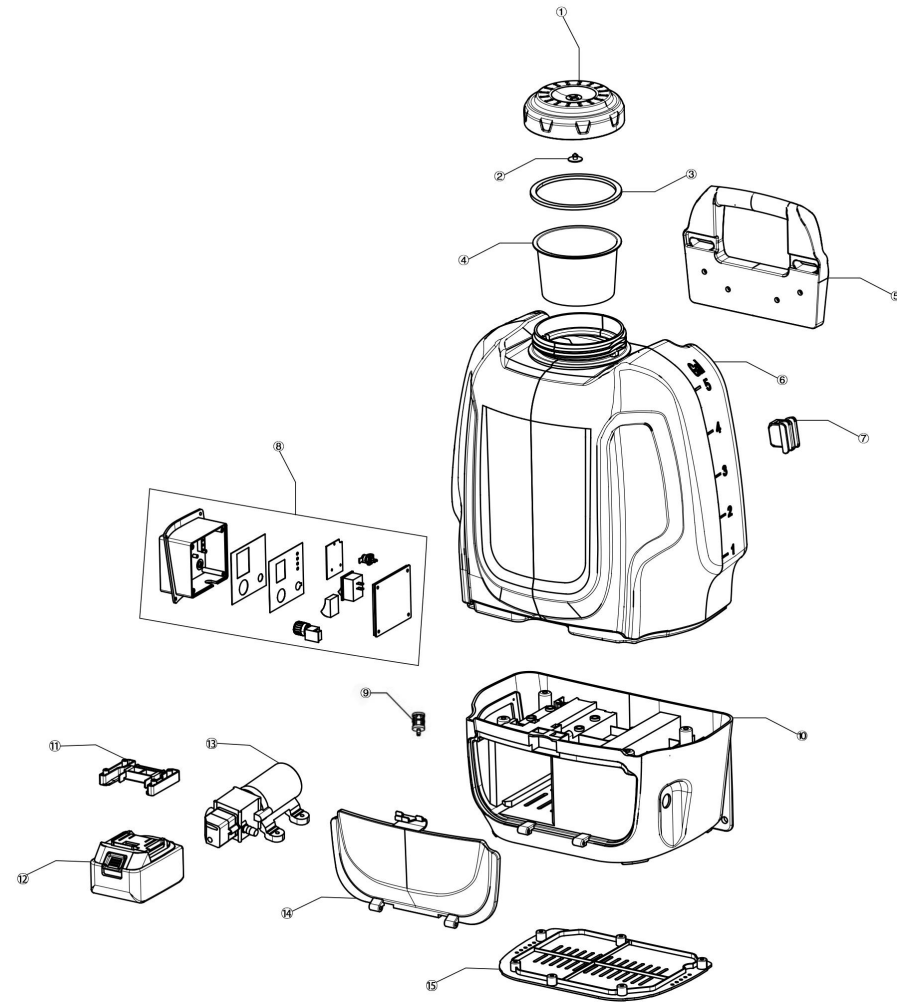

## Product Advantages

### Lifting Handle and Tank Cover



- Special foam rubber sealing ring, better elasticity and leakproofness.
- Concave and convex design tank cover, anti-slip and easy to grasp.
- Humanized curved handle with multi reinforcing ribs more stable and comfortable.



## Product Advantages

### Straps and Backrest

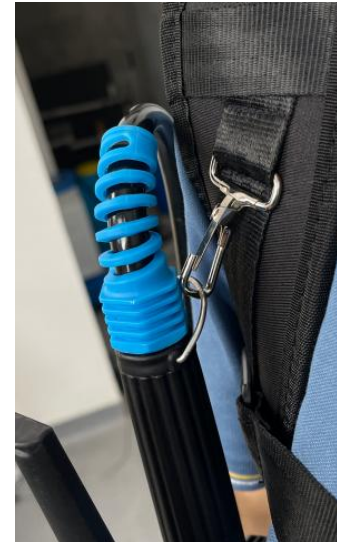

- Multi-functional adjustable straps and backrest, protect the waist and back.
- Adjustable thicken straps with lock catch on the waist and chest.
- Hang the switch on this hook, temporarily free hands.
- Thoughtful storage bag design.

## Product Advantages

### Bottom and Function Area

- Thickened base board with 4 buffer feet to enhance bottom's strength resistance.
- Three separate main areas: control area, battery area, pump area.

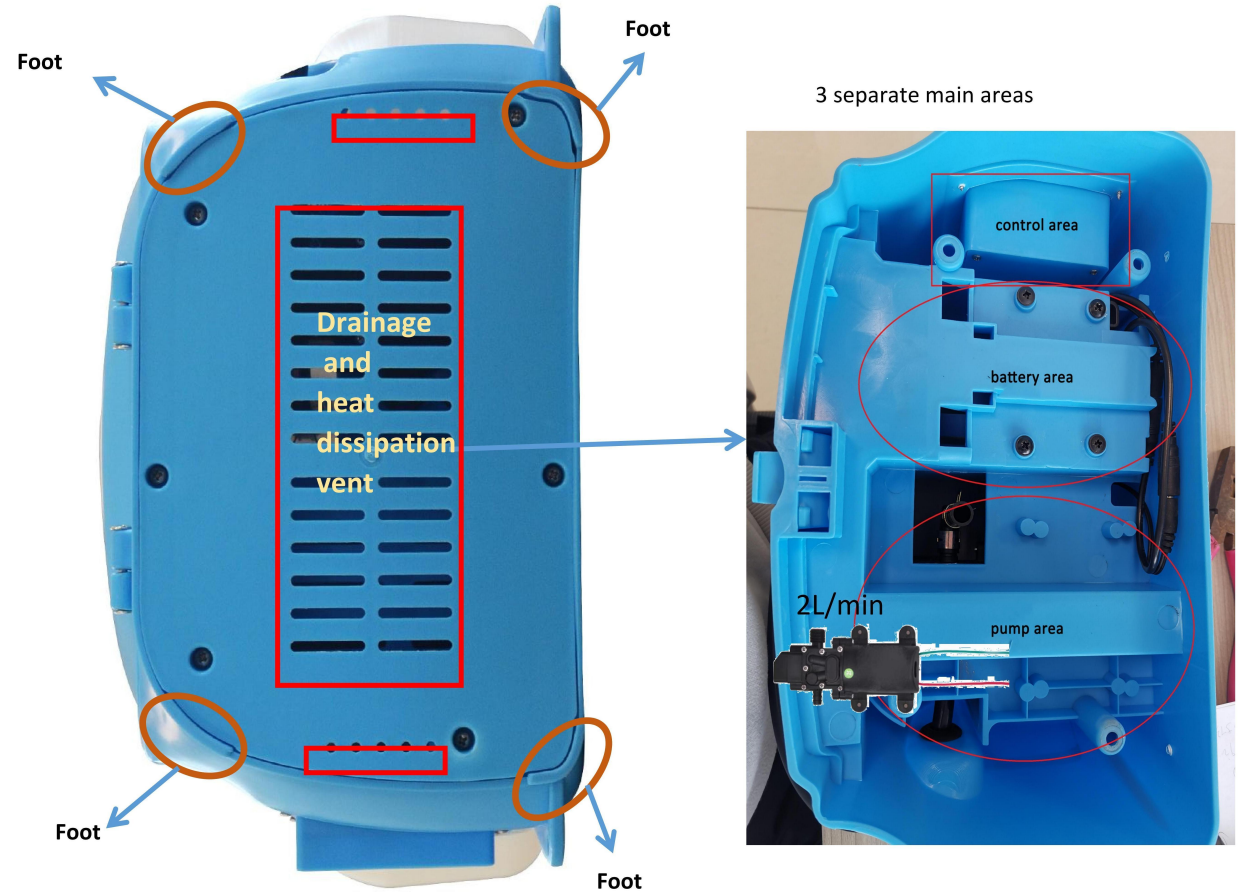

## Product Advantages

### Independent Control Module



- Independent control module design, make the complex circuit simple.
- The protection alarm for too low or too high battery power.

## Product Advantages

### Battery and its compartment

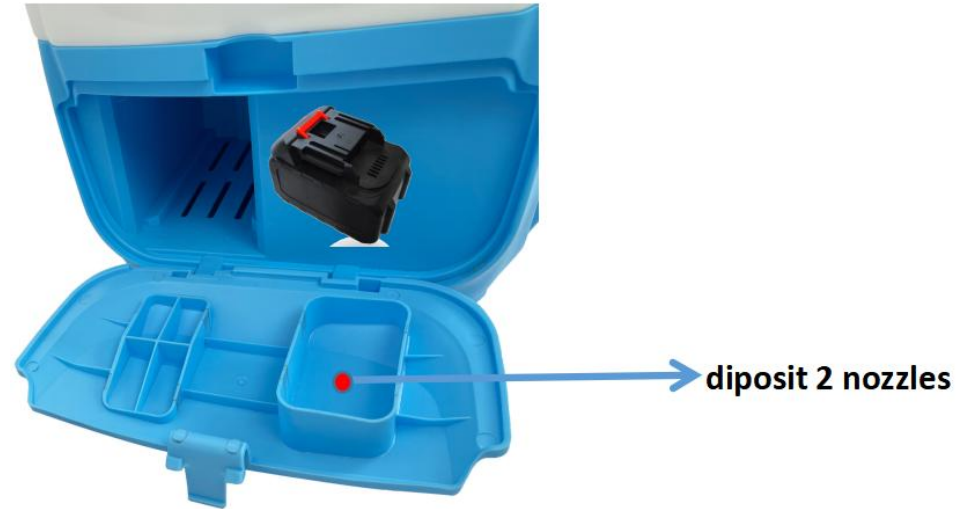

- Battery compartment can suit for 21V/4AH Li-ion and 12V/8AH Lead-acid battery.
- The crisscross reinforcing rids make the whole battery cover stronger.

## Product Advantages—Accessories



21V/4A Quick-connect Lithium Battery  
Charging time: 3-4h, working time: about 5h



2L/min Pressure Pump  
Automatically induct pressure and shut off



304 Food Grade Stainless Steel Lance  
With environmental rubber ring



Three nozzles and storage bag which can print customers' logo.



Customized as customer's request



Switch inside has fluoruous rubber sealing ring  
Blue part can protect 130cm hose not to be deformation

## Product Advantages





Thanks for watching